

Chain washing unit



The inline chain washing unit is designed to run continuously when working with production lines that have a high degree of product spillage. The result is a cleaner chain that allows longer production runs without the need for CIP or routine maintenance.

The chain cleaner prevents product build up on the chain and allows continuous fault free running of the line with the need to stop the conveyor and remove the chain to clean by hand.

Supplied as a complete unit the chain washer can quickly be integrated into new conveyor lines or upgraded to existing conveyor lines in order to improve performance and reliability

Standard features

- **Robust** – the system is robust and designed to operate within harsh environment where spillages on the conveyor are highly likely.
- **Compact** – the unit will take up the smallest footprint possible.
- **Clean** – clean design with sloping faces and minimum areas for fluid or dirt to build up.
- **Safe** – fully guarded design.
- **Simple installation** – mount to conveyors using standard fittings.

System information

The washing unit is available for aluminium conveyor systems XS, XL, X85, XH and XK, and stainless systems XLX and X85X.

Technical specification

Minimum top of chain height 550 mm
Maximum conveyor length 3 m
Maximum conveyor speed 50 m/min

Operating requirements

Water supply attachment

Connection of water/cleaning system is made by G ½" internal thread connection. Maximum/Minimum flowrate required is 11–13,5 l/min.

Drainage Vacuum

Vacuum attachment is made by Ø32 hose connection. Vacuum requirements are 23,5 kPa minimum with a vacuum of 2x56 l/second.

Chain washer

Chain washer

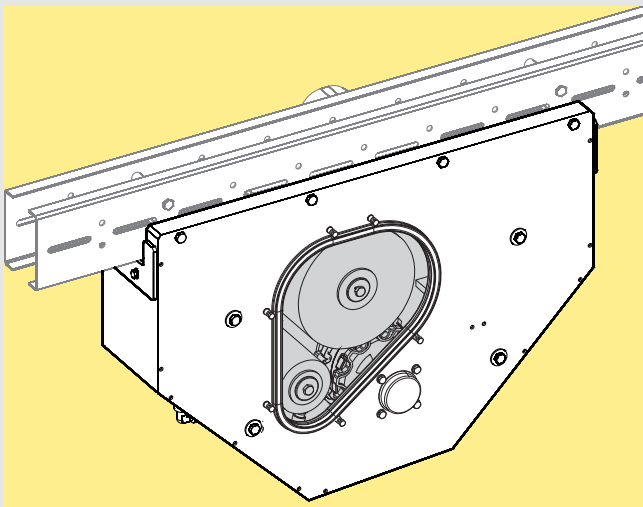

Chain washer	
Chain Washing Unit XS	8044023
Chain Washing Unit XL	8044024
Chain Washing Unit XLX	8044025
Chain Washing Unit X85	8044026
Chain Washing Unit X85X	8044027
Chain Washing Unit XH	8044029
Chain Washing Unit XK	8044028

Note. 1 m long beam section

Spare parts

Spray nozzle	8042716
Brush Ø80	8042673
Brush Ø180	8042672

Note!

The chain washing unit cannot be used with an enclosed or guided type of conveyor drive unit.